



BetaTHERM Sensors

TEMPERATURE SOLUTIONS

Chip Thermistors Epoxy Coated or Leadless

Table of Contents

BetaCURVE Interchangeable thermistor Series I	2
BetaCURVE Interchangeable thermistor Series II	4
BetaCURVE Interchangeable thermistor Series III	6
BetaCURVE Interchangeable thermistor Series IV	7
BetaCURVE Interchangeable thermistor Series V	8
BetaCURVE Medical Grade Thermistor Series VI	9
BetaCHIP Thermistor Series VII	10
BetaLINEAR Series	11
Interchangeable mini-BetaCURVE Probe	14
Micro-BetaCHIP Thermistor Probe	15
Medical Catheter micro-BetaCHIP Probe	16
BetaCHIP Leadless Chip Thermistor	17
Gold Termination BetaCHIP Thermistor	18

BETA ApS (DK + NO): Phone: +45 59 31 11 88, Fax: +45 59 31 12 10, email: beta@beta.dk

BEATA Komponent AB (SE): Phone: +46 (0)392 360 40, Fax: +46 (0)392 360 41, e-mail: beata@beta.dk

BETA Finland OY (FI): Phone: +358 (0)9 260 9209, Fax: +358 (0)9 260 9208, e-mail: betafinland@beta.dk
url: www.beta.dk, www.beata.se, www.betafinland.fi, www.betatherm.com

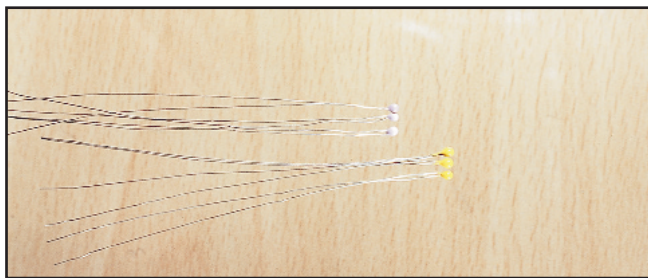

Thermistor Configuration

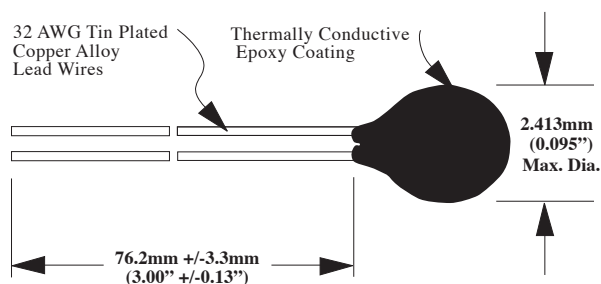

Example: BetaCURVE Series I Part Number

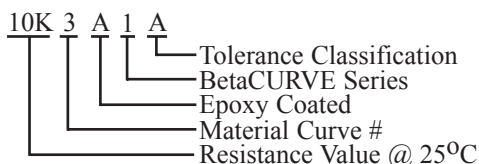

BetaCurve Interchangeable Thermistor Series I

Applications

- Temperature sensing, control and compensation.
- Medical equipment and patient monitoring.
- Aerospace instrumentation and crystal oscillator compensation.
- Liquid or gas temperature control and monitoring.
- Assembly into probes for a wide variety of applications.

Features

- Rapid Time Response (1 second typical in liquids).
- DC (Dissipation Constant) = 0.75mW/°C typical in still air at 25°C.
- Min./Max. Temperature Exposure = -80°C to 150°C.
- Available in custom probe assemblies.
- Proven Stability and Reliability.
- Alloy Lead Wires for reduced thermal conductivity ("stem effect").
- Choice of 4 temperature tolerance classifications.

Tolerance Code:

Specification:

A	+/-0.1°C, 0°C to 70°C
B	+/-0.2°C, 0°C to 70°C
C	+/-0.5°C, 0°C to 70°C
D	+/-1.0°C, 0°C to 70°C

The BetaCURVE Thermistor Series I are small epoxy coated devices with solid tin plated lead wires. The series offers a choice of precision temperature tolerance classifications for a wide variety of customer applications, such as temperature measurements, temperature indication, temperature control, and thermal compensation.

The BetaCURVE Series history of "long term" stability and reliability performance have been demonstrated in critical medical, scientific instrumentation, military/aerospace and industrial applications.

Thermistor interchangeability has become an important factor for cost efficiency in advanced thermal performance applications. The need for expensive individual thermistor calibration is not necessary. The BetaCURVE Series interchangeability means that each device will match the published Resistance-Temperature Characteristics (R-T Tables pages 43 to 47) for a given thermistor and will be within the specified deviation (tolerance, ie. +/-0.1°C, +/-0.2°C, +/-0.5°C and +/-1.0°C) limits over the temperature range 0°C to 70°C.

With the demands of JIT (just in time) deliveries expected in today's manufacturing sector. BetaTHERM maintains high finished goods inventory and dedicated manufacturing to continuously produce the BetaCURVE Series.

BETA ApS (DK + NO): Phone: +45 59 31 11 88, Fax: +45 59 31 12 10, email: beta@beta.dk

BEATA Komponent AB (SE): Phone: +46 (0)392 360 40, Fax: +46 (0)392 360 41, e-mail: beata@beta.dk

BETA Finland OY (FI): Phone: +358 (0)9 260 9209, Fax: +358 (0)9 260 9208, e-mail: betafinland@beta.dk

url: www.beta.dk, www.beata.se, www.betafinland.fi, www.betatherm.com

BetaCURVE Series I Part Numbers and Specifications

Part Number	Color Code	Resistance ohms @ 25°C	Resistance Tolerance@ 25°C	Temperature Tolerance and Range	Alpha @ 25°C	0/50 °C Beta Value	Curve #
2.2K3A1A	Brown	2252	+/- 0.25%	+/- 0.1 °C (0 to 70 °C)	-4.39 %/°C	3892	3
2.2K3A2B	Brown	2252	+/- 0.50%	+/- 0.2 °C (0 to 70 °C)	-4.39 %/°C	3892	3
2.2K3A3C	Brown	2252	+/- 1.00%	+/- 0.5 °C (0 to 70 °C)	-4.39 %/°C	3892	3
2.2K3A4D	Brown	2252	+/- 2.00%	+/- 1.0 °C (0 to 70 °C)	-4.39 %/°C	3892	3
3K3A1A	Red	3000	+/- 0.25%	+/- 0.1 °C (0 to 70 °C)	-4.39 %/°C	3892	3
3K3A1B	Red	3000	+/- 0.50%	+/- 0.2 °C (0 to 70 °C)	-4.39 %/°C	3892	3
3K3A1C	Red	3000	+/- 1.00%	+/- 0.5 °C (0 to 70 °C)	-4.39 %/°C	3892	3
3K3A1D	Red	3000	+/- 2.00%	+/- 1.0 °C (0 to 70 °C)	-4.39 %/°C	3892	3
5K3A1A	Orange	5000	+/- 0.25%	+/- 0.1 °C (0 to 70 °C)	-4.39 %/°C	3892	3
5K3A1B	Orange	5000	+/- 0.50%	+/- 0.2 °C (0 to 70 °C)	-4.39 %/°C	3892	3
5K3A1C	Orange	5000	+/- 1.00%	+/- 0.5 °C (0 to 70 °C)	-4.39 %/°C	3892	3
5K3A1D	Orange	5000	+/- 2.00%	+/- 1.0 °C (0 to 70 °C)	-4.39 %/°C	3892	3
10K3A1A	Yellow	10000	+/- 0.25%	+/- 0.1 °C (0 to 70 °C)	-4.39 %/°C	3892	3
10K3A1B	Yellow	10000	+/- 0.50%	+/- 0.2 °C (0 to 70 °C)	-4.39 %/°C	3892	3
10K3A1C	Yellow	10000	+/- 1.00%	+/- 0.5 °C (0 to 70 °C)	-4.39 %/°C	3892	3
10K3A1D	Yellow	10000	+/- 2.00%	+/- 1.0 °C (0 to 70 °C)	-4.39 %/°C	3892	3
10K4A1A	Black	10000	+/- 0.25%	+/- 0.1 °C (0 to 70 °C)	-4.04 %/°C	3575	4
10K4A1B	Black	10000	+/- 0.50%	+/- 0.2 °C (0 to 70 °C)	-4.04 %/°C	3575	4
10K4A1C	Black	10000	+/- 1.00%	+/- 0.5 °C (0 to 70 °C)	-4.04 %/°C	3575	4
10K4A1D	Black	10000	+/- 2.00%	+/- 1.0 °C (0 to 70 °C)	-4.04 %/°C	3575	4
30K5A1A	White	30000	+/- 0.25%	+/- 0.1 °C (0 to 70 °C)	-4.30 %/°C	3811	5
30K5A1B	White	30000	+/- 0.50%	+/- 0.2 °C (0 to 70 °C)	-4.30 %/°C	3811	5
30K5A1C	White	30000	+/- 1.00%	+/- 0.5 °C (0 to 70 °C)	-4.30 %/°C	3811	5
30K5A1D	White	30000	+/- 2.00%	+/- 1.0 °C (0 to 70 °C)	-4.30 %/°C	3811	5
30K6A1A	Green	30000	+/- 0.25%	+/- 0.1 °C (0 to 70 °C)	-4.68 %/°C	4143	6
30K6A1B	Green	30000	+/- 0.50%	+/- 0.2 °C (0 to 70 °C)	-4.68 %/°C	4143	6
30K6A1C	Green	30000	+/- 1.00%	+/- 0.5 °C (0 to 70 °C)	-4.68 %/°C	4143	6
30K6A1D	Green	30000	+/- 2.00%	+/- 1.0 °C (0 to 70 °C)	-4.68 %/°C	4143	6
50K6A1A	Blue	50000	+/- 0.25%	+/- 0.1 °C (0 to 70 °C)	-4.68 %/°C	4143	6
50K6A1B	Blue	50000	+/- 0.50%	+/- 0.2 °C (0 to 70 °C)	-4.68 %/°C	4143	6
50K6A1C	Blue	50000	+/- 1.00%	+/- 0.5 °C (0 to 70 °C)	-4.68 %/°C	4143	6
50K6A1D	Blue	50000	+/- 2.00%	+/- 1.0 °C (0 to 70 °C)	-4.68 %/°C	4143	6
100K6A1A	Violet	100000	+/- 0.25%	+/- 0.1 °C (0 to 70 °C)	-4.68 %/°C	4143	6
100K6A1B	Violet	100000	+/- 0.50%	+/- 0.2 °C (0 to 70 °C)	-4.68 %/°C	4143	6
100K6A1C	Violet	100000	+/- 1.00%	+/- 0.5 °C (0 to 70 °C)	-4.68 %/°C	4143	6
100K6A1D	Violet	100000	+/- 2.00%	+/- 1.0 °C (0 to 70 °C)	-4.68 %/°C	4143	6



BetaCurve Interchangeable Thermistor Series II

Applications

- Temperature sensing, control and compensation.
- P.C. board mounting for over temperature protection.
- Automotive car seat heater control and engine management.
- Assembly into probes for a wide variety of applications in industrial temperature control and instrumentation.

Features

- Rapid Time Response (1 second typical in liquids).
- DC (Dissipation Constant) = 0.85mW/ °C typical in still air at 25°C.
- Min./Max. Temperature Exposure = -80 to 150°C.
- Available in custom probe assemblies.
- Proven Stability and Reliability.
- Teflon Insulated lead wires.
- Choice of 4 temperature tolerance classifications:

Tolerance Code:	Specification:
A	+/-0.1°C, 0°C to 70°C
B	+/-0.2°C, 0°C to 70°C
C	+/-0.5°C, 0°C to 70°C
D	+/-1.0°C, 0°C to 70°C

Thermistor Configuration

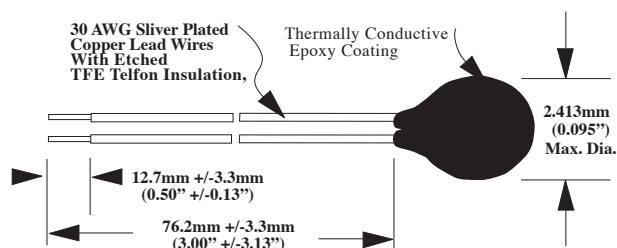

Example: BetaCURVE Series II Part Number

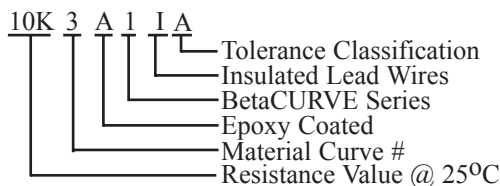

Similar to the *BetaCURVE Thermistor Series I*, the *Series II* thermistors are small epoxy coated devices. The same quality thermistor elements are used during assembly. Series II are manufactured using 30 AWG teflon insulated lead wires. They offer the same choice of precision temperature tolerance classifications for a wide variety of customer applications.

The *Series II* differs from *Series I* marginally with respect to D.C. The typical value of 0.85mW/°C in still air at 25°C is due to the larger lead wire diameter made of pure copper.

The insulated lead wires offer customers the added protection of TFE teflon insulation that has the highest temperature rating (150°C) of the most common insulating materials. TFE teflon is a material that does not bond easily with epoxies or adhesives. For this reason the surface of the teflon wire is etched, which enhances bondability for applications that require mounting or potting the thermistor with epoxies or adhesives.

The series is produced in high volume as a Standard configuration. Other configurations are available on a custom basis. Larger or smaller lead wires can be used with the same chip elements and with insulating materials of PVC, Kynar, Tefzel, Nylon/Polyurethane, etc. Contact Applications Engineering Group for support if requirements differ from the standard configuration as shown above.

BETA ApS (DK + NO): Phone: +45 59 31 11 88, Fax: +45 59 31 12 10, email: beta@beta.dk

4 **BEATA Komponent AB (SE):** Phone: +46 (0)392 360 40, Fax: +46 (0)392 360 41, e-mail: beata@beta.dk

BETA Finland OY (FI): Phone: +358 (0)9 260 9209, Fax: +358 (0)9 260 9208, e-mail: betafinland@beta.dk

url: www.beta.dk, www.beata.se, www.betafinland.fi, www.betatherm.com

BetaCURVE Series II Part Numbers and Specifications:

Part Number	Color Code	Resistance ohms @ 25°C	Resistance Tolerance@ 25°C	Temperature Tolerance and Range	Alpha @ 25°C	0/50 °C Beta Value	Curve #
2.2K3A1IA	Brown	2252	+/- 0.25%	+/- 0.1 °C (0 to 70 °C)	-4.39 %/°C	3892	3
2.2K3A2IB	Brown	2252	+/- 0.50%	+/- 0.2 °C (0 to 70 °C)	-4.39 %/°C	3892	3
2.2K3A3IC	Brown	2252	+/- 1.00%	+/- 0.5 °C (0 to 70 °C)	-4.39 %/°C	3892	3
2.2K3A4ID	Brown	2252	+/- 2.00%	+/- 1.0 °C (0 to 70 °C)	-4.39 %/°C	3892	3
3K3A1IA	Red	3000	+/- 0.25%	+/- 0.1 °C (0 to 70 °C)	-4.39 %/°C	3892	3
3K3A1IB	Red	3000	+/- 0.50%	+/- 0.2 °C (0 to 70 °C)	-4.39 %/°C	3892	3
3K3A1IC	Red	3000	+/- 1.00%	+/- 0.5 °C (0 to 70 °C)	-4.39 %/°C	3892	3
3K3A1ID	Red	3000	+/- 2.00%	+/- 1.0 °C (0 to 70 °C)	-4.39 %/°C	3892	3
5K3A1IA	Orange	5000	+/- 0.25%	+/- 0.1 °C (0 to 70 °C)	-4.39 %/°C	3892	3
5K3A1IB	Orange	5000	+/- 0.50%	+/- 0.2 °C (0 to 70 °C)	-4.39 %/°C	3892	3
5K3A1IC	Orange	5000	+/- 1.00%	+/- 0.5 °C (0 to 70 °C)	-4.39 %/°C	3892	3
5K3A1ID	Orange	5000	+/- 2.00%	+/- 1.0 °C (0 to 70 °C)	-4.39 %/°C	3892	3
10K3A1IA	Yellow	10000	+/- 0.25%	+/- 0.1 °C (0 to 70 °C)	-4.39 %/°C	3892	3
10K3A1IB	Yellow	10000	+/- 0.50%	+/- 0.2 °C (0 to 70 °C)	-4.39 %/°C	3892	3
10K3A1IC	Yellow	10000	+/- 1.00%	+/- 0.5 °C (0 to 70 °C)	-4.39 %/°C	3892	3
10K3A1ID	Yellow	10000	+/- 2.00%	+/- 1.0 °C (0 to 70 °C)	-4.39 %/°C	3892	3
10K4A1IA	Black	10000	+/- 0.25%	+/- 0.1 °C (0 to 70 °C)	-4.04 %/°C	3575	4
10K4A1IB	Black	10000	+/- 0.50%	+/- 0.2 °C (0 to 70 °C)	-4.04 %/°C	3575	4
10K4A1IC	Black	10000	+/- 1.00%	+/- 0.5 °C (0 to 70 °C)	-4.04 %/°C	3575	4
10K4A1ID	Black	10000	+/- 2.00%	+/- 1.0 °C (0 to 70 °C)	-4.04 %/°C	3575	4
30K5A1IA	White	30000	+/- 0.25%	+/- 0.1 °C (0 to 70 °C)	-4.30 %/°C	3811	5
30K5A1IB	White	30000	+/- 0.50%	+/- 0.2 °C (0 to 70 °C)	-4.30 %/°C	3811	5
30K5A1IC	White	30000	+/- 1.00%	+/- 0.5 °C (0 to 70 °C)	-4.30 %/°C	3811	5
30K5A1ID	White	30000	+/- 2.00%	+/- 1.0 °C (0 to 70 °C)	-4.30 %/°C	3811	5
30K6A1IA	Green	30000	+/- 0.25%	+/- 0.1 °C (0 to 70 °C)	-4.68 %/°C	4143	6
30K6A1IB	Green	30000	+/- 0.50%	+/- 0.2 °C (0 to 70 °C)	-4.68 %/°C	4143	6
30K6A1IC	Green	30000	+/- 1.00%	+/- 0.5 °C (0 to 70 °C)	-4.68 %/°C	4143	6
30K6A1ID	Green	30000	+/- 2.00%	+/- 1.0 °C (0 to 70 °C)	-4.68 %/°C	4143	6
50K6A1IA	Blue	50000	+/- 0.25%	+/- 0.1 °C (0 to 70 °C)	-4.68 %/°C	4143	6
50K6A1IB	Blue	50000	+/- 0.50%	+/- 0.2 °C (0 to 70 °C)	-4.68 %/°C	4143	6
50K6A1IC	Blue	50000	+/- 1.00%	+/- 0.5 °C (0 to 70 °C)	-4.68 %/°C	4143	6
50K6A1ID	Blue	50000	+/- 2.00%	+/- 1.0 °C (0 to 70 °C)	-4.68 %/°C	4143	6
100K6A1IA	Violet	100000	+/- 0.25%	+/- 0.1 °C (0 to 70 °C)	-4.68 %/°C	4143	6
100K6A1IB	Violet	100000	+/- 0.50%	+/- 0.2 °C (0 to 70 °C)	-4.68 %/°C	4143	6
100K6A1IC	Violet	100000	+/- 1.00%	+/- 0.5 °C (0 to 70 °C)	-4.68 %/°C	4143	6
100K6A1ID	Violet	100000	+/- 2.00%	+/- 1.0 °C (0 to 70 °C)	-4.68 %/°C	4143	6

BETA ApS (DK + NO): Phone: +45 59 31 11 88, Fax: +45 59 31 12 10, email: beta@beta.dk

BEATA Komponent AB (SE): Phone: +46 (0)392 360 40, Fax: +46 (0)392 360 41, e-mail: beata@beta.dk

BETA Finland OY (FI): Phone: +358 (0)9 260 9209, Fax: +358 (0)9 260 9208, e-mail: betafinland@beta.dk

url: www.beta.dk, www.beata.se, www.betafinland.fi, www.betatherm.com

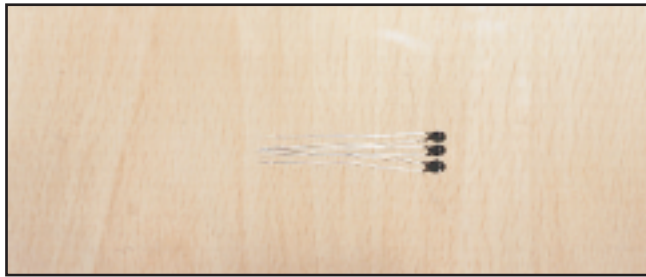

Thermistor Configuration

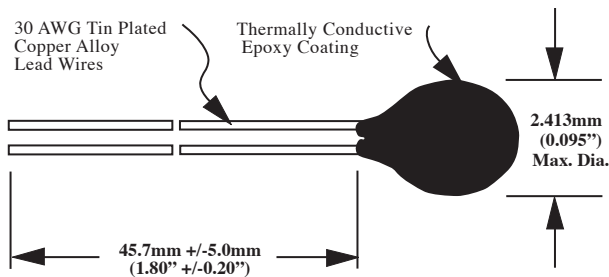

Example: BetaCURVE Series III Part Number

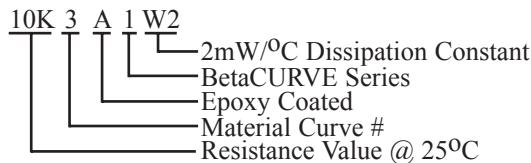

BetaCURVE Interchangeable Thermistor Series III

Applications

- Temperature sensing, control and compensation.
- Applied to applications where higher Dissipation Constant is required (2.0mW/°C).

Features

- Rapid Time Response (1.3 second typical in liquids).
- DC (Dissipation Constant) = 2.0mW/°C typical in still air at 25°C.
- Min./Max. Temperature Exposure = -80°C to 150°C.
- Available in custom probe assemblies.
- Proven Stability and Reliability
- Larger lead wires ease assembly requirements.

BetaCURVE Thermistor Series III are similar in construction to Series I except for the use of larger (30 AWG) copper leads. This allows the Dissipation Constant (D.C.) to be raised from 0.75mW/°C to 2.0mW/°C. Larger leads also facilitate easier handling during assembly operations. The Thermal Time Constant is raised to 14 seconds in air. Custom resistance values and tolerances are available upon request.

BetaCURVE Series III Part Numbers and Specifications:

Part Number	Color Code	Resistance ohms @ 25°C	Resistance Tolerance @ 25°C	Temperature Tolerance and Range	Alpha @ 25°C	0/50°C Beta Value	Curve #
2.2K3A1W2	Brown	2252	+/- 0.50%	+/- 0.2 °C (0 to 70 °C)	-4.39 %/°C	3892	3
3K3A1W2	Red	3000	+/- 0.50%	+/- 0.2 °C (0 to 70 °C)	-4.39 %/°C	3892	3
5K3A1W2	Orange	5000	+/- 0.50%	+/- 0.2 °C (0 to 70 °C)	-4.39 %/°C	3892	3
10K3A1W2	Yellow	10000	+/- 0.50%	+/- 0.2 °C (0 to 70 °C)	-4.39 %/°C	3892	3
10K4A1W2	Black	10000	+/- 0.50%	+/- 0.2 °C (0 to 70 °C)	-4.04 %/°C	3575	4
30K5A1W2	White	30000	+/- 0.50%	+/- 0.2 °C (0 to 70 °C)	-4.30 %/°C	3811	5
30K6A1W2	Green	30000	+/- 0.50%	+/- 0.2 °C (0 to 70 °C)	-4.68 %/°C	4143	6
50K6A1W2	Blue	50000	+/- 0.50%	+/- 0.2 °C (0 to 70 °C)	-4.68 %/°C	4143	6
100K6A1W2	Violet	100000	+/- 0.50%	+/- 0.2 °C (0 to 70 °C)	-4.68 %/°C	4143	6

BETA ApS (DK + NO): Phone: +45 59 31 11 88, Fax: +45 59 31 12 10, email: beta@beta.dk

BEATA Komponent AB (SE): Phone: +46 (0)392 360 40, Fax: +46 (0)392 360 41, e-mail: beata@beta.dk

BETA Finland OY (FI): Phone: +358 (0)9 260 9209, Fax: +358 (0)9 260 9208, e-mail: betafinland@beta.dk

url: www.beta.dk, www.beata.se, www.betafinland.fi, www.betatherm.com



Thermistor Configuration

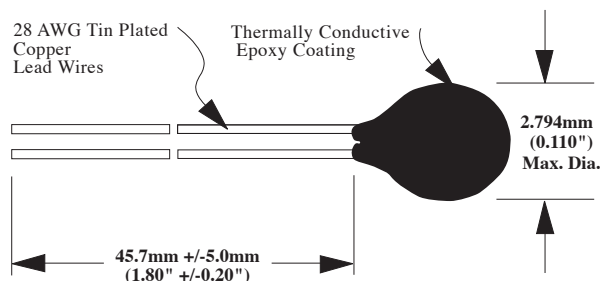

Example: BetaCURVE Series IV Part Number

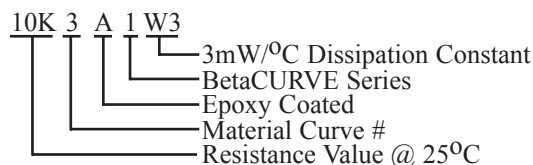

BetaCURVE Interchangeable Series IV

Applications:

- Temperature sensing, control and compensation.
- Applications where a Dissipation Constant of 3.0 mW/°C is required.

Features:

- Rapid Time Response (1.5 second, typical in liquids).
- DC (Dissipation Constant) = 3.0mW/°C typical in still air at 25°C.
- Min./Max. Temperature Exposure = -80°C to 150°C.
- Available in custom probe assemblies.
- Proven Stability and Reliability

BetaTherm Thermistor Series IV provides a higher Dissipation Constant (3.0mW/°C) allowing design engineers greater flexibility on sensor design projects. The higher D.C. is achieved using 28 AWG tin plated copper lead wires and also larger chip thermistor elements. These chip elements are manufactured using the same high quality materials and manufacturing process as Series I. Custom resistance values and tolerances are available upon request.

BetaCURVE Series IV Part Numbers and Specifications:

Part Number	Color Code	Resistance ohms @ 25°C	Resistance Tolerance @ 25°C	Temperature Tolerance and Range	Alpha @ 25°C	0/50 °C Beta Value	Curve #
2.2K3A1W3	Brown	2252	+/- 0.50%	+/- 0.2 °C (0 to 70 °C)	-4.39 %/°C	3892	3
3K3A1W3	Red	3000	+/- 0.50%	+/- 0.2 °C (0 to 70 °C)	-4.39 %/°C	3892	3
5K3A1W3	Orange	5000	+/- 0.50%	+/- 0.2 °C (0 to 70 °C)	-4.39 %/°C	3892	3
10K3A1W3	Yellow	10000	+/- 0.50%	+/- 0.2 °C (0 to 70 °C)	-4.39 %/°C	3892	3
10K4A1W3	Black	10000	+/- 0.50%	+/- 0.2 °C (0 to 70 °C)	-4.04 %/°C	3575	4
30K5A1W3	White	30000	+/- 0.50%	+/- 0.2 °C (0 to 70 °C)	-4.30 %/°C	3811	5
30K6A1W3	Green	30000	+/- 0.50%	+/- 0.2 °C (0 to 70 °C)	-4.68 %/°C	4143	6
50K6A1W3	Blue	50000	+/- 0.50%	+/- 0.2 °C (0 to 70 °C)	-4.68 %/°C	4143	6
100K6A1W3	Violet	100000	+/- 0.50%	+/- 0.2 °C (0 to 70 °C)	-4.68 %/°C	4143	6



Thermistor Configuration

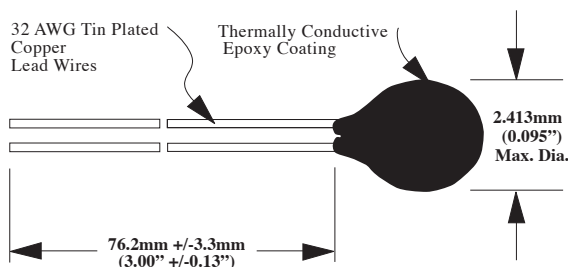

Example: BetaCURVE Series V Part Number

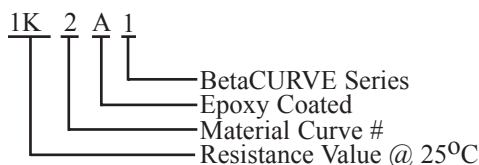

BetaCURVE Interchangeable Thermistor Series V

Applications

- Widely used for cold temperature environments.
- Artificial snow making equipment.
- Temperature compensation.
- Automotive air conditioning.

Features

- Rapid Time Response (1 second typical in liquids).
- DC (Dissipation Constant) = 0.75mW/°C typical in still air at 25°C.
- Min./Max. Temperature Exposure = -80°C to 125°C.
- Available in custom probe assemblies.
- Proven Stability and Reliability

The BetaCURVE Thermistor Series V are small epoxy coated devices with solid tin plated lead wires. Due to the low nominal resistance values, these devices are suitable for measurement applications at the lower temperature ranges. The use of tin plated copper wires minimize the effects of lead wire resistance. Series V is specified with a temperature tolerance of +/-0.2°C over the range -20°C to 50°C. Resistance - temperature tables are given on pages 43 to 47 for each of the thermistor types listed below. The series does not offer color coding (all thermistor in this series are coated with black epoxy).

BetaCURVE Interchangeable Series V Part Numbers and Specifications:

Part Number for +/- 5% @ 25 °C	Color Code	Resistance @ 25 °C (ohms)	Resistance Tolerance @ 25 °C	Temperature Tolerance and Range	Alpha @ 25 °C	0/50°C Beta Value	Curve #
0.1K1A1	Black	100	+/-0.50%	+/-0.2 °C 0 °C to 50 °C	-3.50%	3108	1
0.3K1A1	Black	300	+/-0.50%	+/-0.2 °C 0 °C to 50 °C	-3.50%	3108	1
1K2A1	Black	1000	+/-0.50%	+/-0.2 °C 0 °C to 50 °C	-3.68%	3263	2
1K7A1	Black	1000	+/-0.50%	+/-0.2 °C 0 °C to 50 °C	-3.87%	3422	7

BETA ApS (DK + NO): Phone: +45 59 31 11 88, Fax: +45 59 31 12 10, email: beta@beta.dk

BEATA Komponent AB (SE): Phone: +46 (0)392 360 40, Fax: +46 (0)392 360 41, e-mail: beata@beta.dk

BETA Finland OY (FI): Phone: +358 (0)9 260 9209, Fax: +358 (0)9 260 9208, e-mai: betafinland@beta.dk

url: www.beta.dk, www.beata.se, www.betafinland.fi, www.betatherm.com



Thermistor Configuration

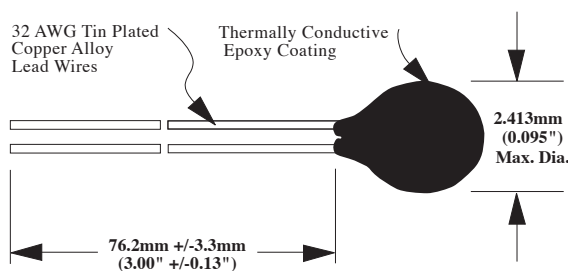

Example: BetaCURVE Series VI Part Number

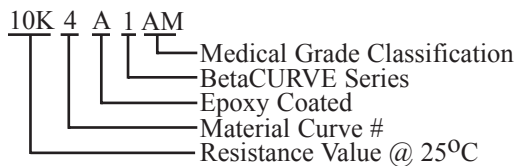

BetaCURVE Medical Grade Thermistor Series VI:

Applications

- Oxygen sensing equipment and instruments.
- Esophageal Catheters
- Skin sensors
- Oral and Rectal Probes
- Pharmaceutical manufacturing equipment

Features

- Rapid Time Response (1 second typical in liquids).
- DC (Dissipation Constant) = 0.75mW/°C typical in still air at 25°C.
- Min./Max. Temperature Exposure = -80°C to 150°C.
- Available in custom probe assemblies.
- Proven Stability and Reliability

The BetaCURVE Thermistor Series VI are small epoxy coated devices with solid tin plated lead wires. The Series VI is specified with a temperature tolerance of +/- 0.05°C over the range from 32°C to 44°C and is available in different nominal resistance values. Each thermistor element is manufactured using high quality materials and processes. High accuracy temperature baths (+/-0.005°C) are used during all stages of assembly and final testing.

This special series is offered to the **Medical Industry** for both new and existing applications. These devices are also useful in the pharmaceutical manufacturing equipment sector.

Custom resistance values and tolerances are available upon request.

BetaCURVE Medical Grade Series VI Part Numbers and Specifications:

Part Number +/- 5% @ 25°C	Color Code	Resistance @ 25°C (ohms)	Temperature Tolerance and Range	Alpha @ 25°C	0/50°C Beta Value	Curve #
2.2K3A1AM	Brown	2252	+/-0.05 °C 32 °C to 44 °C	-4.39%	3892	3
10K3A1AM	Yellow	10000	+/-0.05 °C 32 °C to 44 °C	-4.39%	3892	3
10K4A1AM	Black	10000	+/-0.05 °C 32 °C to 44 °C	-4.04%	3575	4

BETA ApS (DK + NO): Phone: +45 59 31 11 88, Fax: +45 59 31 12 10, email: beta@beta.dk

BEATA Komponent AB (SE): Phone: +46 (0)392 360 40, Fax: +46 (0)392 360 41, e-mail: beata@beta.dk

BETA Finland OY (FI): Phone: +358 (0)9 260 9209, Fax: +358 (0)9 260 9208, e-mai: betafinland@beta.dk

url: www.beta.dk, www.beata.se, www.betafinland.fi, www.betatherm.com



Thermistor Configuration

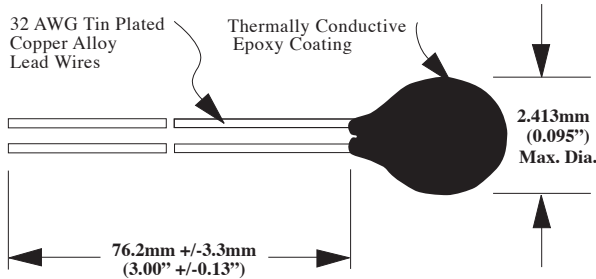

Example: BetaCHIP Series VII Part Number

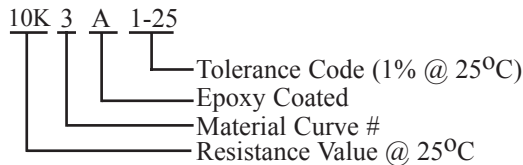

BetaCHIP Thermistor Series VII

Applications

- Ambient temperature sensing, control and compensation.
- Aerospace instrumentation and crystal oscillator compensation.
- Liquid or gas temperature control and monitoring.
- Assembly into probes for a wide variety of applications.

Features

- Rapid Time Response (1 second typical in liquids).
- DC (Dissipation Constant) = 0.75mW/°C typical in still air at 25°C.
- Min./Max. Temperature Exposure = -80°C to 150°C.
- Available in custom probe assemblies.
- Proven Stability and Reliability.
- Alloy Lead Wires for reduced thermal conductivity ("stem effect").

The BetaCHIP +/-1% @ 25°C Thermistor Series are small epoxy coated devices with solid tin plated lead wires. The series offers an economical alternative to the precision BetaCURVE Series for a wide variety of customer applications such as temperature control and thermal compensation where less precision will perform in the application.

The series is useful in applications where the temperature range is near room temperature (25°C). Predicted deviations across the complete temperature range are given in BetaTHERM Resistance Multipliers-Temperature and Deviation Tolerance Tables on pages 48 and 49.

BetaCHIP Series VII Part Numbers and Specifications:

Part Number	Resistance @ +25°C	Alpha @ +25 °C	0/50 °C Beta Value	Curve #
0.1K1A1-25	100	-3.50%	3108	1
0.3K1A1-25	300	-3.50%	3108	1
1K2A1-25	1000	-3.68%	3263	2
1K7A1-25	1000	-3.87%	3422	7
2K3A1-25	2000	-4.39%	3892	3
2.2K3A1-25	2252	-4.39%	3892	3
3K3A1-25	3000	-4.39%	3892	3
5K3A1-25	5000	-4.39%	3892	3
10K3A1-25	10000	-4.39%	3892	3
10K4A1-25	10000	-4.04%	3575	4
30K5A1-25	30000	-4.30%	3811	5
30K6A1-25	30000	-4.68%	4143	6
50K6A1-25	50000	-4.68%	4143	6
100K6A1-25	100000	-4.68%	4143	6
1M9A1-25	1000000	-5.18%	4582	9

BETA ApS (DK + NO): Phone: +45 59 31 11 88, Fax: +45 59 31 12 10, email: beta@beta.dk

BEATA Komponent AB (SE): Phone: +46 (0)392 360 40, Fax: +46 (0)392 360 41, e-mail: beata@beta.dk

BETA Finland OY (FI): Phone: +358 (0)9 260 9209, Fax: +358 (0)9 260 9208, e-mail: betafinland@beta.dk

url: www.beta.dk, www.beata.se, www.betafinland.fi, www.betatherm.com

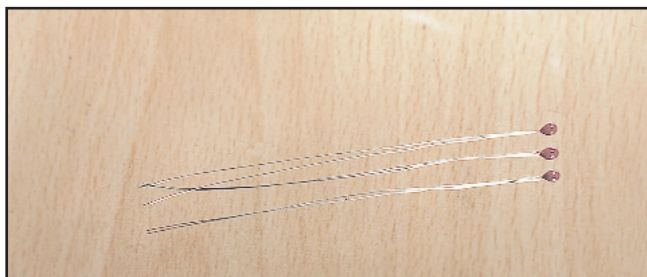

36K53A1 Configuration

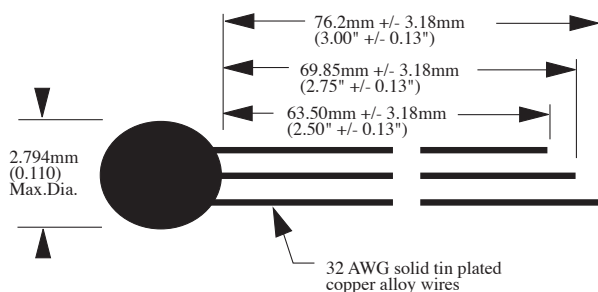

The *BetaLINEAR Series* is offered in different configurations which allows customers a choice for various applications. The configuration options shown are standard and are referred to as linear composites to which precision resistors of specific value are added to create a linear response of voltage or resistance verses a change in body temperature. The linear response is limited to specific temperature ranges. Also, the degree of accuracy (tolerance) will vary depending on the temperature span.

The linear composite is made from two or three sensor elements. The most popular composite (36K53A1 or D1) is made with two elements (30K5 and 6K3), hence the three lead composite. To assist the identification of the elements, the leads are cut at different lengths for the 36K53A1 composite and are color coded for the D1 composites.

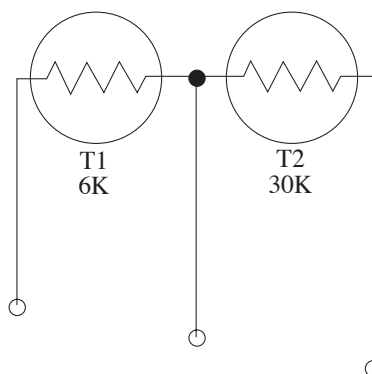

36K53D1 and 11K2M4D1 Configuration

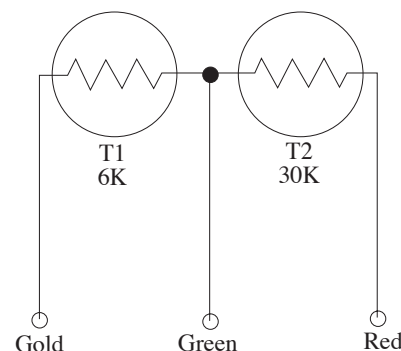
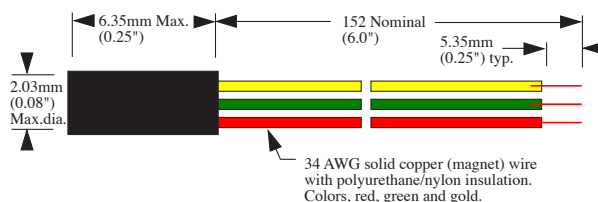

62K345D1 Configuration

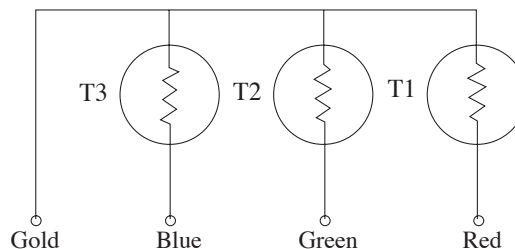
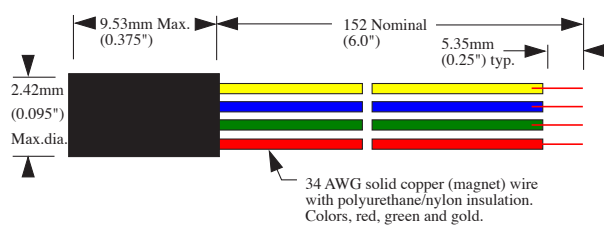

The **BetaLINEAR** circuit designs consist of two sub groupings - precision resistors and thermistors - which when connected can be operated as a single device for either linear voltage or linear resistance response vs. temperature. The circuit designs shown can accommodate a wide variety of circuit mounting options. Options include remote locations of custom thermistor probes and P.C. board mounting precision resistors or packaging resistors and thermistors within a custom probe design.

Linear thermistor network circuits are ideally suited for digital readout systems to measure temperatures in the range from -30°C to 100°C. Sensitivity is superior to Platinum and other metal RTD devices with minimum effect of lead resistance on accuracy. **BetaLINEAR** thermistor circuits can provide up to 400 times the output of a thermocouple with no need for junction temperature or lead wire compensation.

Resistance Mode Output for 36K53A1 (D1) Networks.

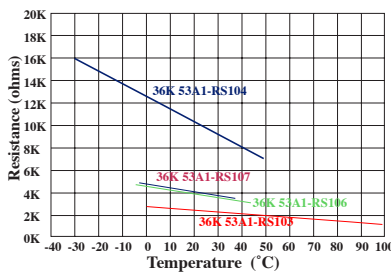

Voltage Mode Negative slope output for 36K53A1(D1) Networks

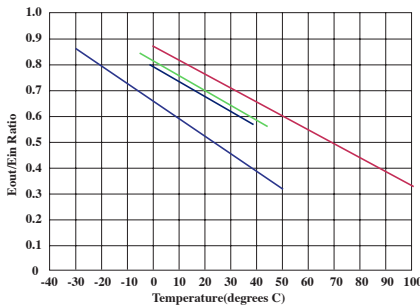

Voltage Mode Positive slope output for 36K53A1(D1) Networks

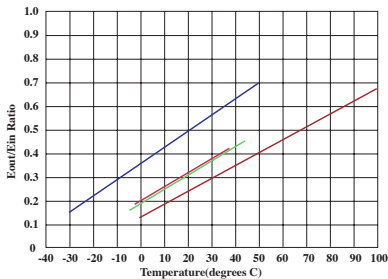

Resistance Mode Schematic For BetaLINEAR 36K53A1, D1 and 11K2M4D1 composites with assigned resistor sets.

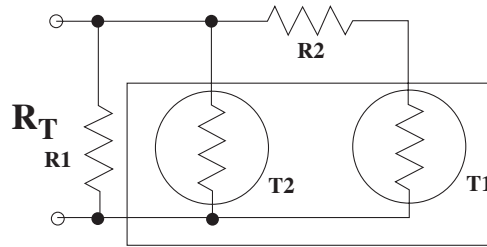

Resistance Mode Schematic For 62K345D1 with assigned resistor set.

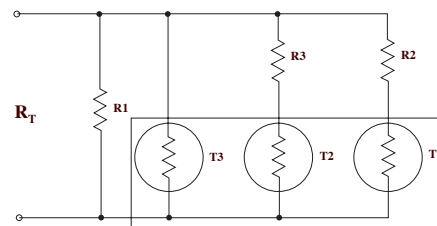

Voltage Mode Schematic For 36K53A1 (D1) and 11K2M4D1 composites with assigned resistor sets.

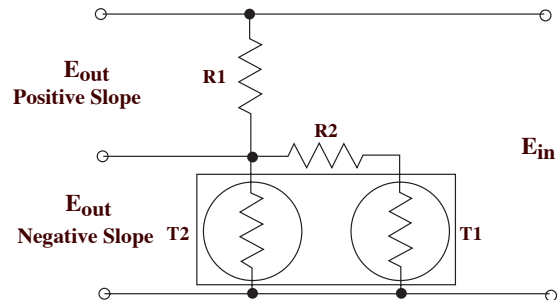

Voltage Mode Schematic For 62K345D1 composite with assigned resistor set.

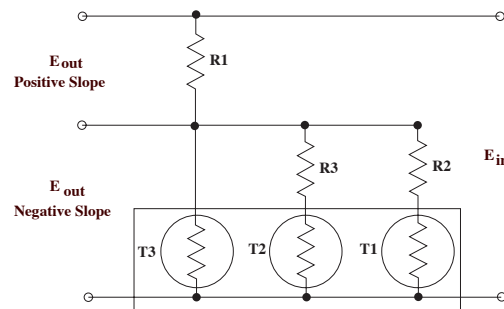

BetaLINEAR Part Numbers and Specifications.

Temp. Range	Composite Part Numbers	Network Part Number	Resistor Set Part Number (ohms)	Eout Positive Slope Eout Negative Slope	Resistance Mode	E _{in} Max.	I _T Max microAmps	Linearity Deviation degrees °C
0 to 100 °C	36K53A1 36K53D1	36K53A1-RS103 36K53D1-RS1030	RS103 R1=3200 +/-0.1% R2=6250 +/-0.1%	E _o = (+0.0053482E _{in})T+0.13494E _{in} E _o = (-0.0053482E _{in})T+0.86506E _{in}	R _t =(-17.114)T+2768.24	2.0Volts	624	+/-0.217
-30 to 50 °C	36K53A1 36K53D1	36K53A1-RS104 36K53D1-RS104	RS104 R1=18700 +/-0.1% R2=35250 +/-0.1%	E _o = (+0.0067967E _{in})T+0.34892E _{in} E _o = (-0.0067967E _{in})T+0.65106E _{in}	R _t =(-127.095)T+12176	3.0Volts	474	+/-0.161
-5 to 45 °C	36K53A1 36K53D1	36K53A1-RS106 36K53D1-RS106	RS106 R1=5700 +/-0.1% R2=12000 +/-0.1%	E _o = (+0.0056847E _{in})T+0.19414E _{in} E _o = (-0.0056847E _{in})T+0.805857E _{in}	R _t =(-32.403)T+4593.4	3.5Volts	610	+/-0.070
-2 to 38 °C	36K53A1 36K53D1	36K53A1-RS107 36K53D1-RS107	RS107 R1=5700 +/-0.1% R2=12400 +/-0.1%	E _o = (+0.00563181E _{in})T+0.192435E _{in} E _o = (-0.00563181E _{in})T+0.807561E _{in}	R _t =(-32.101)T+4603.15	4.0Volts	680	+/-0.035
-55 to 85 °C	11K2M4D1	D1-RS105 11K2M4	RS105 R1=3550 +/-0.1% R2=6025 +/-0.1%	E _o = (+0.005069E _{in})T+0.3410E _{in} E _o = (-0.005069E _{in})T+0.6590E _{in}	R _t =(-18.0)T+2338	2.0Volts	830	+/-1.12
-50 to 50 °C	62K345D1	62K345D1-RS108	RS108 R1=23100 +/-0.1% R2=88200 +/-0.1% R2=88200 +/-0.1%	E _o = (+0.0055915E _{in})T+0.407E _{in} E _o = (-0.0055915E _{in})T+0.593E _{in}	R _t =(-129.162)T+13698.2	3.5Volts	675	+/-0.10

- The overall accuracy of the linear networks are a combination of the thermistor element precision (+/-0.2°C from 0°C to 70°C), uncertainty due to +/-0.1% resistor tolerance and the linearity deviation.
- E_{in} Max and I_T Max values are assigned to control thermistor self-heat errors. Thermistor Dissipation Constant of 8mW/°C in a well stirred oil bath is typical for each thermistor.
- Higher E_{in} Max and I_T Max values may be used when thermistor mounting methods increase the D.C. or an increase of the error is acceptable. E_{in} Max and I_T Max values may be exceeded without any damage to the thermistor elements.

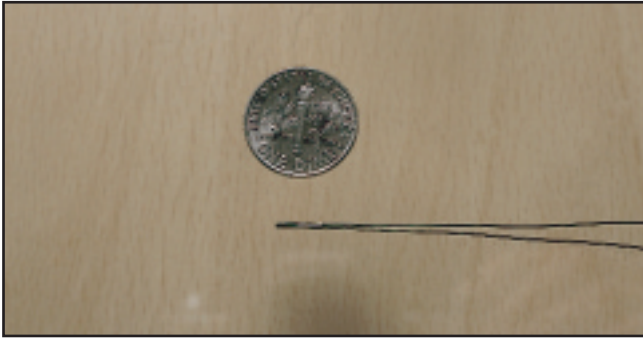

Thermistor Configuration

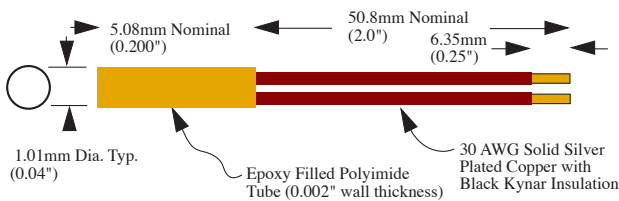

Sample Part Number:

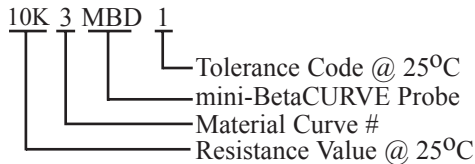

Interchangeable mini-BetaCURVE Probe:

Applications:

- Reduced size allows localized temperature sensing.
- Small Medical probes.
- Micro-flow sensing.
- Aerospace temperature sensing.

Features:

- Rapid Time Constant (400 milliseconds in liquids).
- Standards supplied with +/-0.2°C tolerance (0 to 70°C).
- Other tolerances available.
- 0.5 mW/°C typ. Dissipation Constant in air at 25°C.
- Smaller than regular BetaCURVE Series

The mini-BetaCURVE Probe is an extension of the BetaCURVE Series for applications that require smaller size. Although the mini-BetaCURVE Probe is packaged in polyimide tubing it is recommended that a moisture protection barrier should be used in applications where high humidity is present. The probes relatively small size allows for high precision sensing where the standard BetaCURVE series products are too large or too slow with respect to their thermal Time Constant. The size is compatible with mounting in stainless steel probe housings that have a nominal outside diameter of 1.524mm (0.06").

Interchangeable mini-BetaCURVE Probe Part Numbers and Specifications:

Part Number	Resistance @ 25 °C (Ohms)	Alpha @ 25 °C	0/50 °C Beta Value	Curve #
0.1K1MBD1	100	-3.50%	3108	1
0.3K1MBD1	300	-3.50%	3108	1
1K2MBD1	1000	-3.68%	3263	2
1K7MBD1	1000	-3.87%	3422	7
2.2K3MBD1	2252	-4.39%	3892	3
3K3MBD1	3000	-4.39%	3892	3
5K3MBD1	5000	-4.39%	3892	3
10K3MBD1	10000	-4.39%	3892	3
10K4MBD1	10000	-4.04%	3575	4
30K5MBD1	30000	-4.30%	3811	5
30K6MBD1	30000	-4.68%	4143	6
50K6MBD1	50000	-4.68%	4143	6
100K6MBD1	100000	-4.68%	4143	6
1M9MBD1	1000000	-5.18%	4582	9



Micro-BetaCHIP Probe:

Applications

- Low volume flow sensors (liquids or gases).
- Laboratory animal research.
- Peltiere (thermal cooler) temperature tracking sensors.
- Temperature control for bath showers.
- DNA research sensors.
- Medical catheters.

Features:

- Rapid Time Constant (200 milliseconds in liquids).
- Custom tolerances available.
- 0.3 mW/°C typ. Dissipation Constant in air at 25°C.
- Smaller than our mini-BetaCURVE device.

Thermistor Configuration

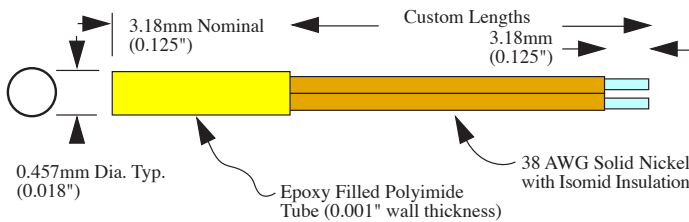

The micro-BetaCHIP probe is BetaTHERM's smallest packaged thermistor device. The probe is produced for applications that require rapid temperature response and applications where space is very limited. The probes are extremely small (0.457mm dia.) and fragile. The sensor is potted in a polyimide tube with epoxy. Adequate moisture protection should be provided when using the device in high humidity applications. The size of the micro-BetaCHIP thermistors allows it to be installed in 20 AWG (0.914mm dia.) thin wall hypodermic tubing. Custom probe assemblies protect the thermistor element from high humidity and mechanical shock.

The small mass of the unit allows the sensor to respond very rapidly to temperature changes. This makes the micro-BetaCHIP thermistor suitable for low volume gas or liquid flow sensing. The probes are also small enough to be mounted inside Medical catheters.

Sample Part Number:

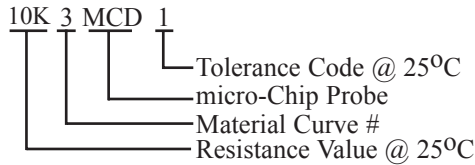

Interchangeable mini-BetaCURVE Probe Part Numbers and Specifications:

Part Number	Resistance @ 25 °C (ohms)	Temperature Tolerance	Alpha @ 25 °C	0/50 °C Beta Value	Curve #
2K7MCD1	2000	+/-0.2 °C @ 25 °C	-3.87%	3422	7
10K3MCD1	10000	+/-0.2 °C @ 25 °C	-4.39%	3892	3
100K6MCD1	100000	+/-0.2 °C @ 25 °C	-4.68%	4143	6

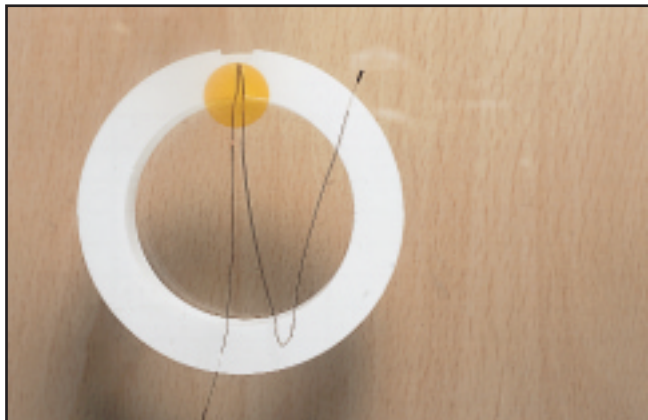

Medical Catheter micro-BetaCHIP Probe:

Applications

- **Thermodilution catheters and other medical applications.**
- **General Medical applications.**

Features:

- **Rapid Time Constant (200 milliseconds in liquids).**
- **Custom tolerances available.**
- **0.3 mW/°C typ. Dissipation Constant in air at 25°C.**
- **Smaller than the mini-BetaCURVE device.**
- **Custom designs available.**

Thermistor Configuration

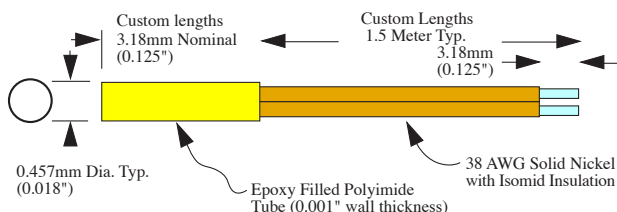

The *Medical Catheter micro-BetaCHIP* probe is packaged similar to the standard micro-BetaCHIP Probe except that the thermistor element is a glass coated thermistor of specific resistance value. The glass coated thermistor adds extra moisture protection to the probe design.

The probe is produced for Medical applications which require rapid temperature response and very small size. When used in thermodilution catheters, the thermistor measures blood flow characteristics in the human body. Supplied with custom lead lengths near 1.5 meters on small reels (spools) with calibration data at 37°C. The standard thermistor is denoted as G22K7MCD8. Many other custom versions have been produced by *BetaTHERM* to meet customers specific design criteria.

Sample Part Number:

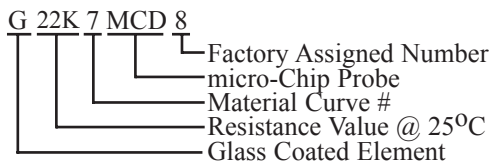

Medical Catheter micro-BetaCHIP Probe Part Number and Specifications:

Part Number	Resistance @ 25 °C (ohms)	Resistance (ohms) and Tolerance @ 37 °C	Alpha @ 25 °C	0/50 °C Beta Value	Curve #
G22K7MCD8	22000	14004 +/- 15%	-3.87%	3422	7

Silver Terminations (Contacts)

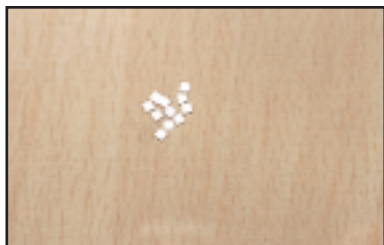

TYPICAL CHIP THERMISTOR

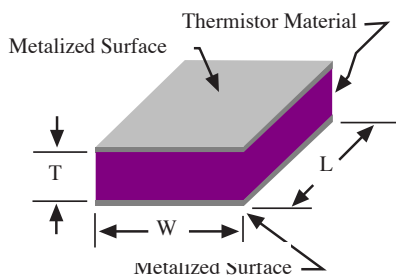

Example: Silver Terminated Leadless BetaCHIP

Part Number

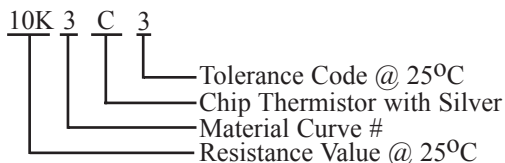

BetaCHIP Leadless Chip Thermistors:

Applications:

- Automotive temperature controls.
- Surface mounting on hybrid circuits.
- Temperature compensation of crystal oscillators.

Features:

- Rapid Time Response (< 1 second typical in liquids).
- Standards supplied with 5% and 10% tolerance.
- 1% and 2% available upon request.
- Surface Mount Capability.
- 1 mW/°C Dissipation Constant in air at 25°C.
- Uniformly Sized for Pick & Place Assembly.

Silver Metalized BetaCHIP Thermistors:

An economical alternative to the gold leadless BetaCHIP thermistors is the Silver terminated leadless BetaCHIP thermistors. These elements are manufactured using the same high quality materials as our other thermistor products. The nominal dimensions remain the same for both gold and silver chips. Custom sizes are also manufactured for customer specific applications. Silver chip elements are supplied in vials, "gel" or "waffle" packs.

Silver metalized chips may be soldered or conductive epoxied to board termination points. The use of solder containing a small quantity of silver is recommended such as 62%Sn (tin), 36%Pb (lead) and 2%Ag (silver).

Silver Terminated Leadless BetaCHIP Thermistor Part Numbers and Specifications:

Part Number for +/- 5% @ 25 °C	Part Number for +/- 10% @ 25°C	Resistance @ 25 °C (ohms)	Alpha @ 25 °C	0/50 °C Beta Value	Curve #	Nominal Chip Dimensions (mm)			Nominal Chip Dimensions (in)		
						L	W	T	L	W	T
0.1K1C3	0.1K1C2	100	-3.50%	3108	1	1.397	1.397	0.305	0.055	0.055	0.012
0.3K1C3	0.3K1C2	300	-3.50%	3108	1	0.914	0.914	0.381	0.036	0.036	0.015
1K2C3	1K2C2	1000	-3.68%	3263	2	0.762	0.762	0.381	0.030	0.030	0.015
1K7C3	1K7C2	1000	-3.87%	3422	7	1.067	1.067	0.381	0.042	0.042	0.015
2.2K3C3	2.2K3C2	2252	-4.39%	3892	3	1.905	1.905	0.254	0.075	0.075	0.010
3K3C3	3K3C2	3000	-4.39%	3892	3	1.651	1.651	0.254	0.065	0.065	0.010
5K3C3	5K3C2	5000	-4.39%	3892	3	1.397	1.397	0.305	0.055	0.055	0.012
10K3C3	10K3C2	10000	-4.39%	3892	3	1.016	1.016	0.305	0.040	0.040	0.012
10K4C3	10K4C2	10000	-4.04%	3575	4	1.143	1.143	0.254	0.045	0.045	0.010
30K5C3	30K5C2	30000	-4.30%	3811	5	0.889	0.889	0.381	0.035	0.035	0.015
30K6C3	30K6C2	30000	-4.68%	4143	6	1.397	1.397	0.305	0.055	0.055	0.012
50K6C3	50K6C2	50000	-4.68%	4143	6	1.143	1.143	0.381	0.045	0.045	0.015
100K6C3	100K6C2	100000	-4.68%	4143	6	0.889	0.889	0.381	0.035	0.035	0.015
1M9C3	1M9C2	1000000	-5.20%	4582	9	0.889	0.889	0.254	0.035	0.035	0.010

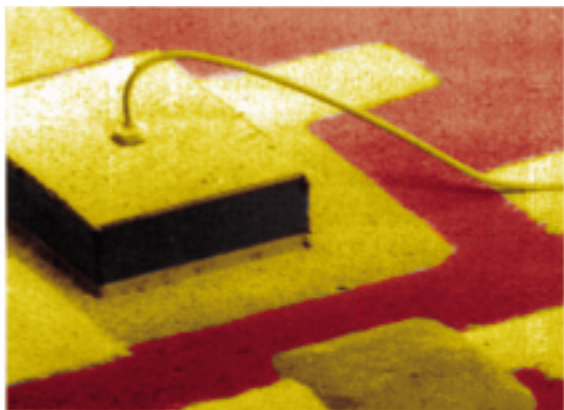

SEM Photo 30x Hybrid Thermistor Chip

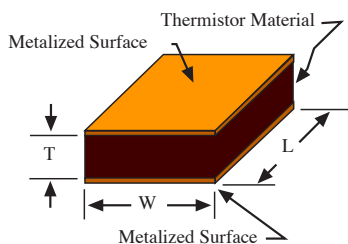
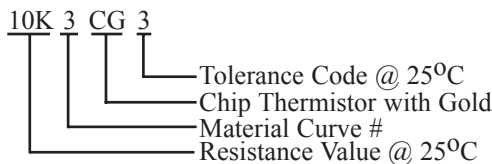

Figure # 1

Sample Part Number:**Gold Termination BetaCHIP Thermistors:****Applications**

- WDM (Wavelength Division Multiplexing) for advanced frequency control in modern communications systems and wireless applications.
- Thermopile sensors for thermal radiation recognition and infrared sensing.
- Thermal protection of sensitive circuits.
- Hybrid circuit temperature compensation.
- Localized temperature sensing.

Features:

- Rapid Time Response (<1 second typical in liquids).
- Standards supplied with 5% and 10% tolerance.
- 1% and 2% available upon request.
- Surface Mount Capability.
- 1 mW/°C Dissipation Constant in air at 25°C.
- Uniformly Sized for Pick & Place Assembly.
- Higher precision tolerance available.
- Square and Rectangular Configurations.

BetaTHERM offer high reliability **Gold** terminated leadless BetaCHIP thermistors that meet today's hybrid microelectronics needs and are offered by BetaTHERM. With metalization on top and bottom surfaces, attachment to hybrid, IC or PC circuits is accomplished using industry standard die attach and wire bonding techniques. Chips may be soldered or conductive epoxied to board termination points where space is at a premium. Typical chip sizes (1mm x 1mm x 0.25mm thick) allow for accurate robotic placement. **Gold BetaCHIP** thermistors are supplied in "gel" or "waffle" packs.

Gold Metalized BetaCHIP Thermistor Part Numbers and Specifications:

Part Number for +/- 5% @ 25 °C	Part Number for +/- 10% @ 25°C	Resistance @ 25 °C (ohms)	Alpha @ 25 °C	0/50 °C Beta Value	Curve #	Nominal Chip Dimensions (mm)			Nominal Chip Dimensions (in)		
						L	W	T	L	W	T
0.1K1CG3	0.1K1CG2	100	-3.50%	3108	1	1.397	1.397	0.305	0.055	0.055	0.012
0.3K1CG3	0.3K1CG2	300	-3.50%	3108	1	0.914	0.914	0.381	0.036	0.036	0.015
1K2CG3	1K2CG2	1000	-3.68%	3263	2	0.762	0.762	0.381	0.030	0.030	0.015
1K7CG3	1K7CG2	1000	-3.87%	3422	7	1.067	1.067	0.381	0.042	0.042	0.015
2.2K3CG3	2.2K3CG2	2252	-4.39%	3892	3	1.905	1.905	0.254	0.075	0.075	0.010
3K3CG3	3K3CG2	3000	-4.39%	3892	3	1.651	1.651	0.254	0.065	0.065	0.010
5K3CG3	5K3CG2	5000	-4.39%	3892	3	1.397	1.397	0.305	0.055	0.055	0.012
10K3CG3	10K3CG2	10000	-4.39%	3892	3	1.016	1.016	0.305	0.040	0.040	0.012
10K4CG3	10K4CG2	10000	-4.04%	3575	4	1.143	1.143	0.254	0.045	0.045	0.010
30K5CG3	30K5CG2	30000	-4.30%	3811	5	0.889	0.889	0.381	0.035	0.035	0.015
30K6CG3	30K6CG2	30000	-4.68%	4143	6	1.397	1.397	0.305	0.055	0.055	0.012
50K6CG3	50K6CG2	50000	-4.68%	4143	6	1.143	1.143	0.381	0.045	0.045	0.015
100K6CG3	100K6CG2	100000	-4.68%	4143	6	0.889	0.889	0.381	0.035	0.035	0.015
1M9CG3	1M9CG2	1000000	-5.20%	4582	9	0.889	0.889	0.254	0.035	0.035	0.010

BETA ApS (DK + NO): Phone: +45 59 31 11 88, Fax: +45 59 31 12 10, email: beta@beta.dk

BEATA Komponent AB (SE): Phone: +46 (0)392 360 40, Fax: +46 (0)392 360 41, e-mail: beata@beta.dk

BETA Finland OY (FI): Phone: +358 (0)9 260 9209, Fax: +358 (0)9 260 9208, e-mail: betafinland@beta.dk

url: www.beta.dk, www.beata.se, www.betafinland.fi, www.betatherm.com